

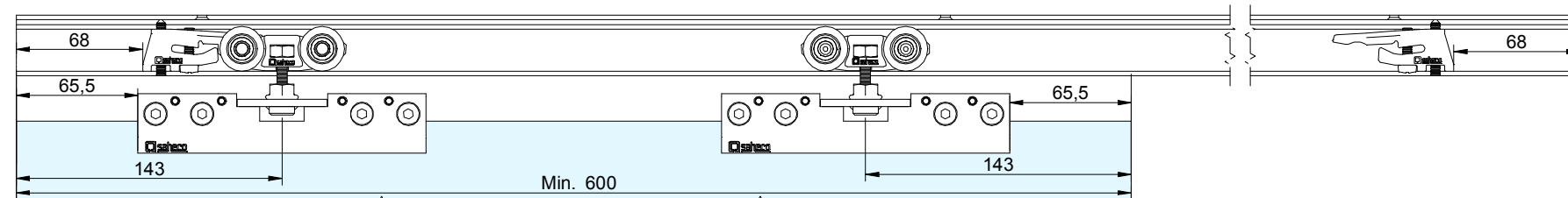

a		2	d		1
b		2	e		2
c		2	f		1

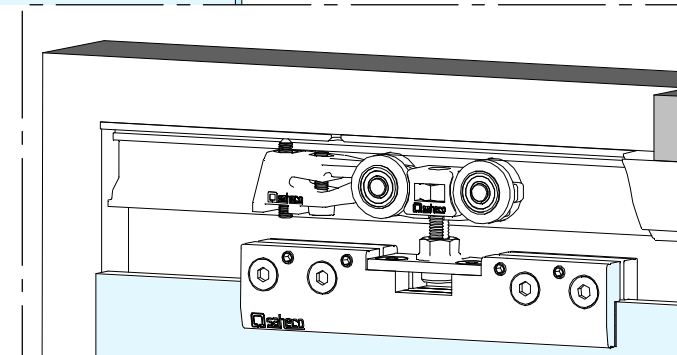

PERFIL STANDARD / Profile Standard / Profil Standard

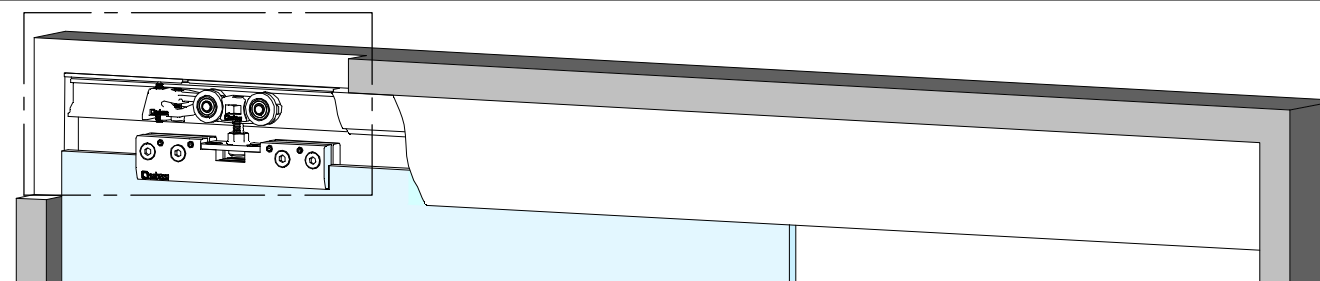
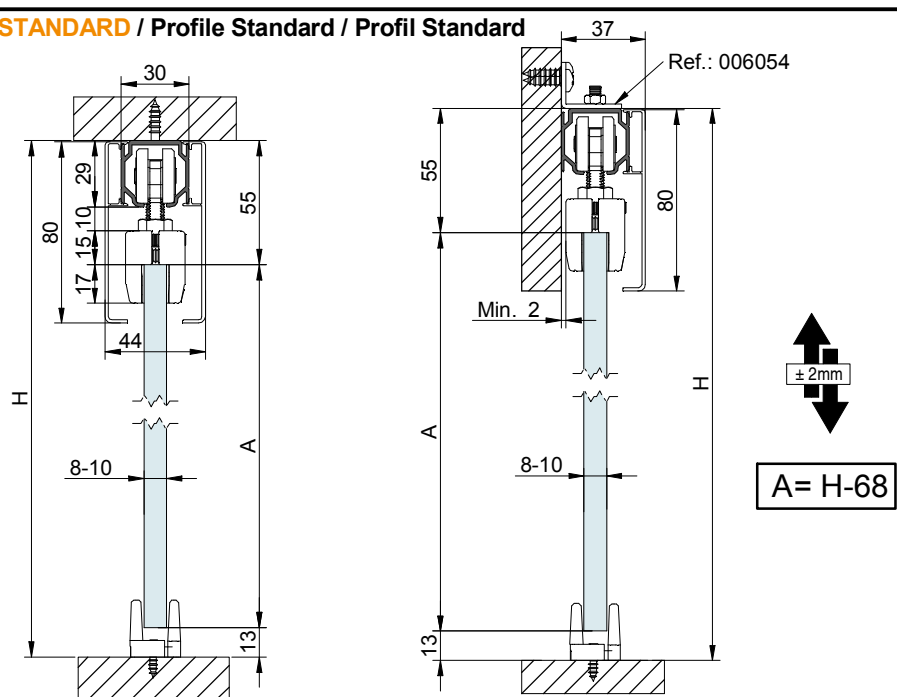

PERFIL EXCELLENCE / Profile Excellence / Profil Excellence

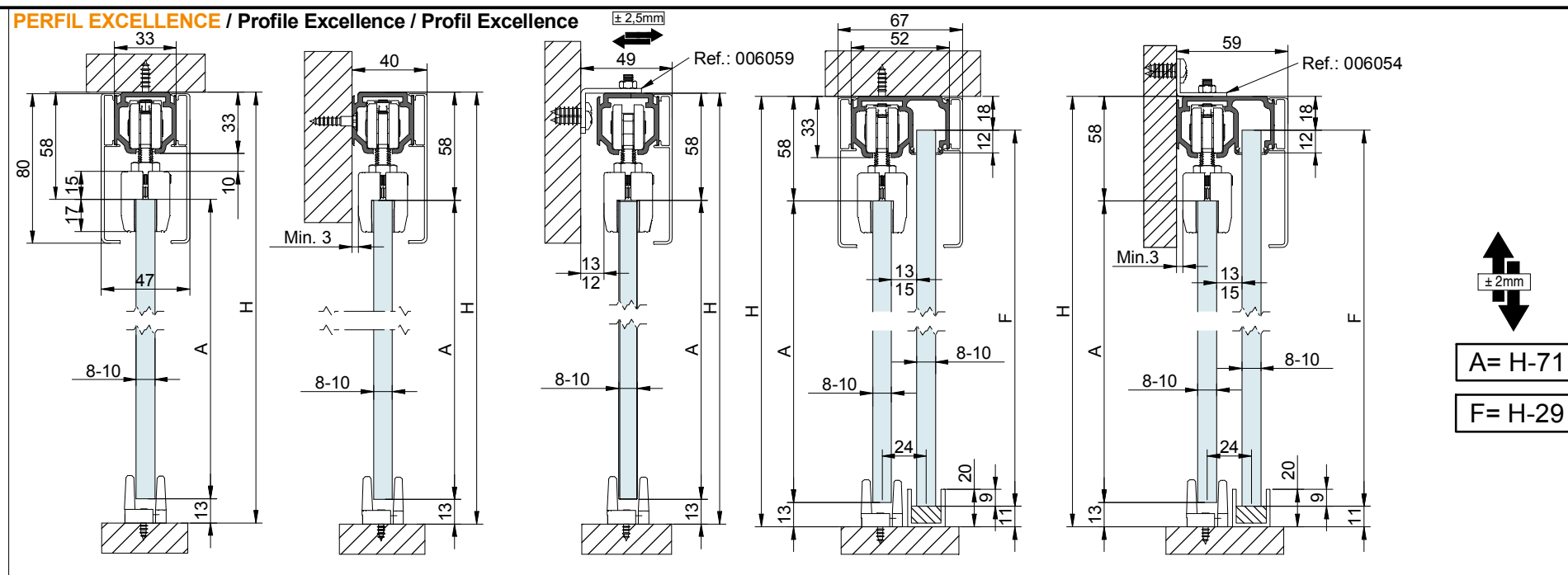

PERFIL STAR / Profile Star / Profil Star

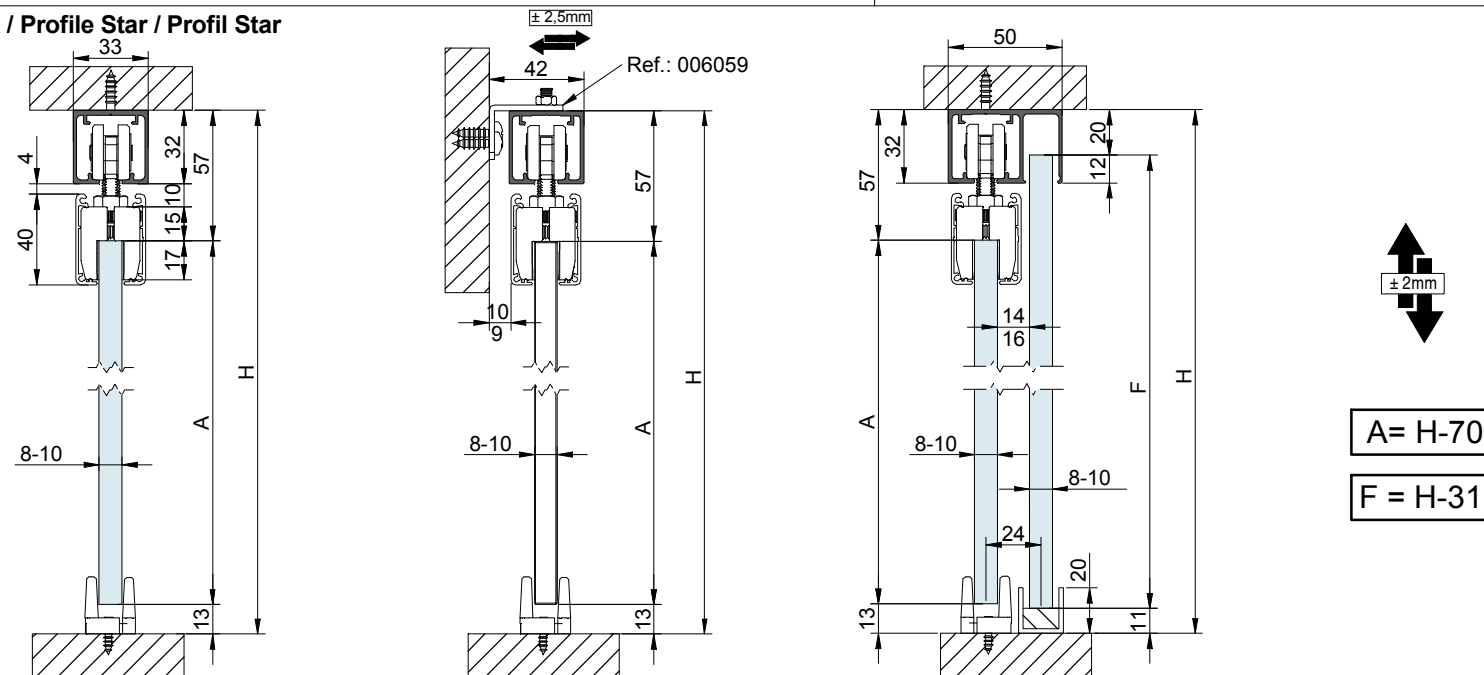

PERFIL STAR FALSO TECHO / Profile Star for plasterboard / Profil Star pour plaques en plâtre

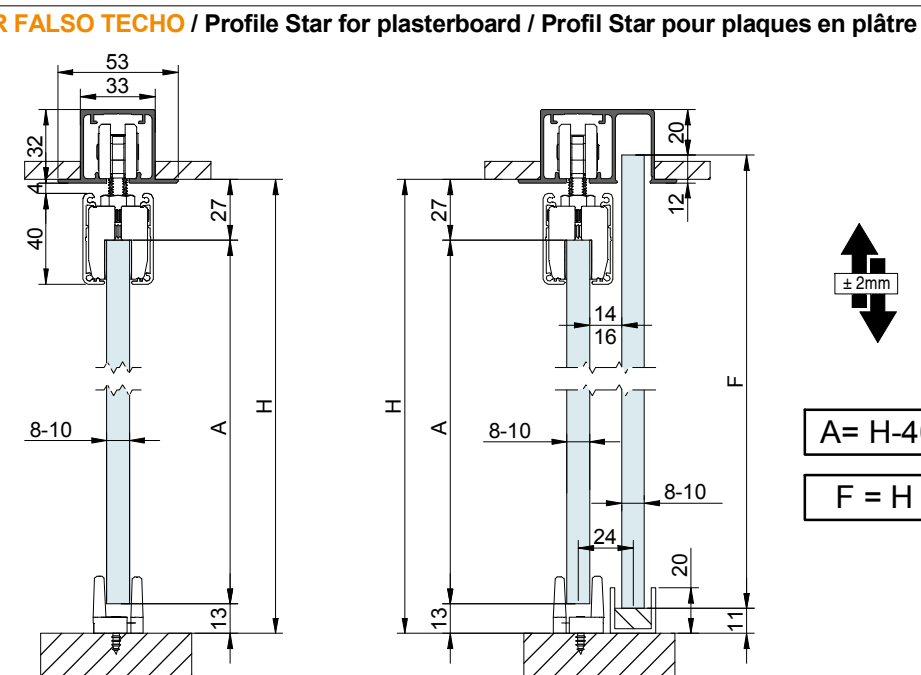

1 MONTAJE A TECHO / Ceiling mount / Fixation à plafond

STANDARD

EXCELLENCE

STAR

2 MONTAJE A PARED / Wall mount / Fixation à plafond

STANDARD

EXCELLENCE

STAR

3 MONTAJE COMPONENTES / Assembly components / Composant d'assemblage

4

TENSAR FRENO RETENEDOR
Tighten retainer brake
Serrer le frein de retenue

FIJAR FRENO RETENEDOR
Set retainer brake
Régler le frein de retenue

5 MONTAJE PINZAS / Calmps assembly / Assemblages pinces

6

PRIMER PASO: AJUSTAR TORNILLOS AJUSTE GROSOR VIDRIO
FIRST STEP: ADJUST GLASS THICKNESS SCREWS

SEGUNDO PASO: APRETAR TORNILLOS APRIETE PINZA
SECOND STEP: STRENGTH CLAMP THIGTHEN SCREWS

13 N/m

7

TERCER PASO: APRETAR TORNILLOS AJUSTE GROSOR VIDRIO
THIRD STEP: STRENGTH THE GLASS THICKNESS SCREWS

90°

±2mm

MONTAJE GUIADOR / Guide mount / Assemblage guide

7

REF.: 00 40 57

MONTAJE TAPETA
Pelmet cover mount
Bandeau à clipser sur rail

8

TAPETAS LATERALES / Cover caps / Capuchons finals

9

CODE: 008074

10 TAPETA EASY LARGE / EASY LARGE pelmet cover / Cache-pince EASY LARGE